

HTT2

Series Controller



Product Category

1. Furniture application
2. Medical applications
3. Industrial application
4. Automotive applications
5. Security applications

Download 3D model



The HTT2 control box developed by GeMinG is designed for various lifting height adjustable applications. The use of solid-state circuitry ensures smooth, noise-free performance, eliminating the buzz associated with relays in traditional systems. Button response is instant and smooth, providing users with an excellent experience, making movements feel smooth and uninterrupted. Paired with the TS6 operator, users can adjust the workspace to any height and level as they wish, and experience excellent operating accuracy. 485, CAN and other communications can be used to achieve precise control operations.

Functional Overview

Input voltage:	110~240V AC
The output voltage:	24V DC~36V DC
Output Power:	300W, 12A
Control motor:	2
Exterior color:	black
Plug type:	Supports European, American, Australian, British or Japanese regulations
Other options:	Wireless remote control and wired operator available
communication method:	Operator control
Installation dimensions:	203 x 96mm
temperature range:	+5°C~+45°C

Drawings

Standard size
MM

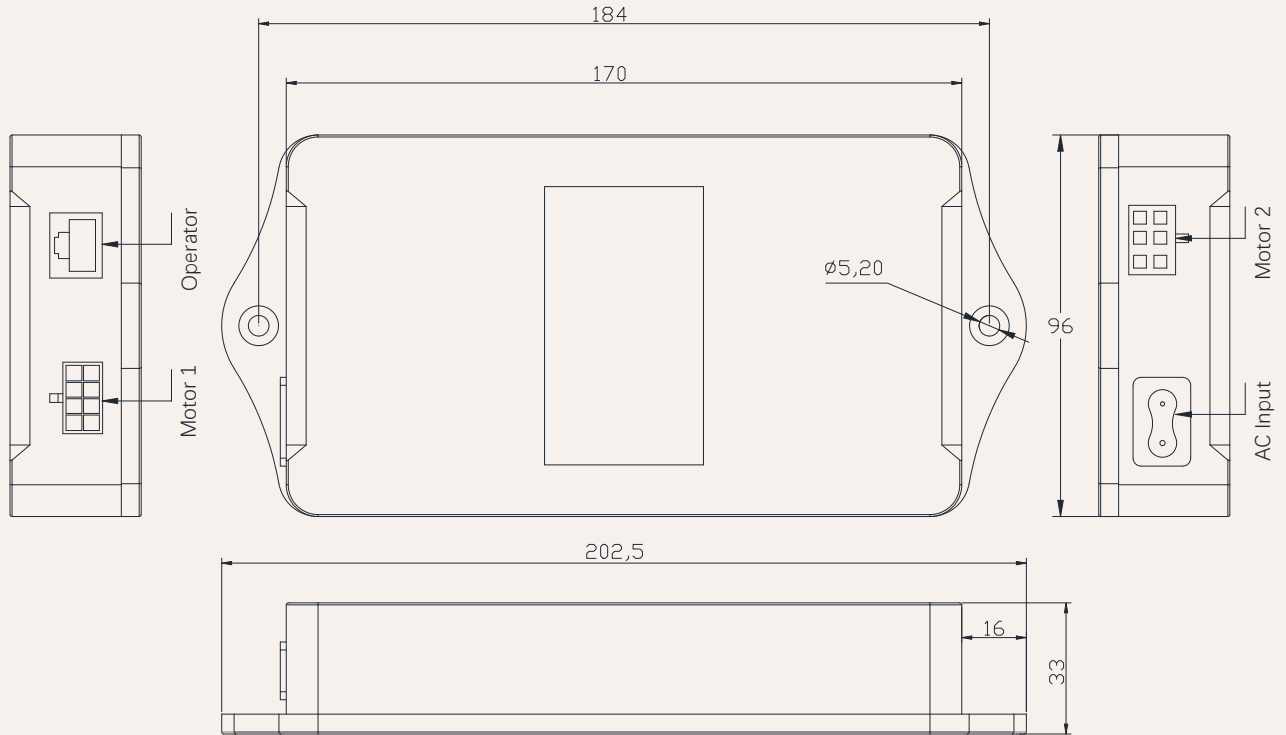

HTT2 Model Description Selection Code Table

HTT2 - 22 - 1 - 1 - 15
 ① ② ③ ④ ⑤

①	Product number	HTT2			
②	Input voltage	22 = 110-240V AC			
③	Operation method	1 = Wired operator	2 = wireless remote	3 = 485 communication control	4 = CAN communication control
④	Plug type	1 = National Standard 2 = European standard	3 = American Standard 4 = Australian Standard	5 = British Standard 6 = Customized	
⑤	Enter wire length	15 = 1500mm 50 = 5000mm	20 = 1000mm 60 = 6000mm	30 = 1500mm 70 = 7000mm	40 = 4000mm 00 = Customized

SYNCHRONOUS CONTROL SYSTEM OPERATING INSTRUCTIONS

1、KEYBOARD INTERFACE EXAMPLE

Button Description:



- Setting Key SET S,M
- Save key 1
- Save key 2
- Save key 3
- Save key 4
- Up key 5 UP
- Down key 6 DOWN

2、INITIALIZATION OPERATION

- When the system is abnormal, or the hand controller displays "RST", the electric lifting actuator needs to be initialized. The initialization operation is to press and hold the "DOWN" button until the actuator stops and then release the button, then press "DOWN" for 5S to automatically enter the initialization mode. The "DOWN" button cannot be released at this time. If the "DOWN" button is released, the system stops the initialization mode. When the initialization is completed, the buzzer will sound a prompt, indicating that the initialization is successful.

3、Up and down key operation

- When the "UP" button is pressed, the electric lift actuator moves upward until it reaches the highest point of the electric lift actuator.
- When the "DOWN" key is pressed, the electric lift actuator moves downward until it reaches the lowest point of the electric lift actuator.
- When the "UP" or "DOWN" key is pressed shortly, the electric lifting actuator will run a small distance accordingly to achieve inching.

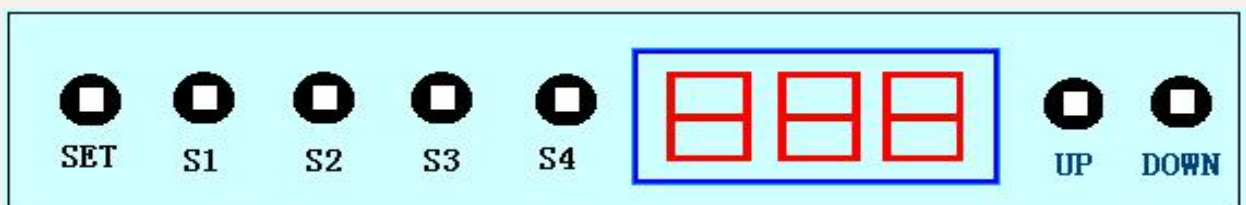

The Updated Keyboard

◀ 产品图

◀ 尺寸图

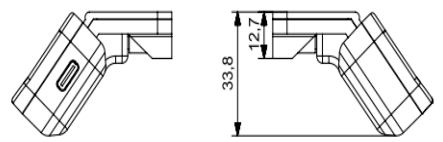
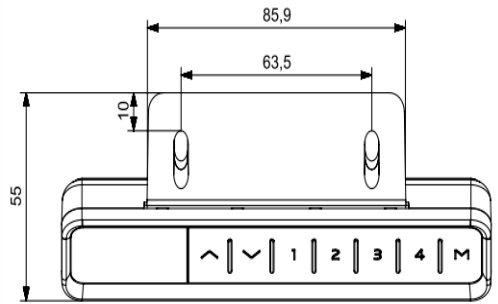
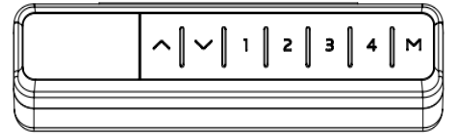

4、 POSITION STORAGE AND MEMORY OPERATION

- The hand controller in the above picture can store 4 memory points. The storage method is as follows: when it runs to a specific point, press the "SET" button, the digital tube displays "S-" and the "-" flashes at the same time. Press the "1-4" button to store the current position to the corresponding number.
- In the fully automatic mode (S-6 is 1), if you want to run to the memory point, you only need to press the label of the corresponding storage position. At this time, the digital tube will display the height of the corresponding label position, and then automatically run to the corresponding height of the position storage. During operation, any key can stop the system.
- In semi-automatic mode (S-6 is 0), if you want to run to the memory point, you only need to keep pressing the label of the corresponding storage position. At this time, the digital tube will display the height of the corresponding label position, and then automatically run to the corresponding height of the position storage. During running, release the button to stop the system.

5、 HIGH AND LOW LIMIT SETTINGS

- The system supports the high and low height limits of the electric lift actuator. The operation method is: when you want to set the current height as the electric lift actuator limit height, press and hold the "UP" + "DOWN" buttons for 5 seconds at the corresponding height. At this time, you will hear a buzzer sound, indicating that the limit position is stored successfully. When the electric lift actuator is in the upper half of the stroke, the limit is the high position. When the electric lift actuator is in the lower half of the electric lift actuator stroke, the limit is the lowest position.
- Cancel the restricted height Method 1: Reset the system at this time, and the system height and low limits are cancelled. Method 2: Let the electric lift actuator run to the restricted high point or low point, and then press and hold the "UP" + "DOWN" buttons for 5 seconds. You will hear a buzzer sound, indicating that the restricted position has been successfully cancelled.

6、 LOCKING AND UNLOCKING

- Lock: Press and hold "SET" + "UP" for 5 seconds. When the digital tube displays "Loc", it means that the system has been locked and cannot be raised or lowered.
- Unlock: Press and hold "SET" + "DOWN" for 5 seconds. When the digital tube changes from "Loc" to normal digital display, it means the system has been unlocked.

7、 RESTORE FACTORY SETTINGS

- When the system is replaced with a new electric lifting actuator, or the parameters need to be restored to the factory settings, press "UP+DOWN" for 10 seconds at the same time and hear a long buzzer prompt. At this time, the parameters are restored to the factory state and forced to initialize.

9、 AUTOMATED TESTING

- Specific hand controllers support automatic testing of the system running for 2 minutes and stopping for 18 minutes. The test range is from the position stored in S1 to the position stored in S2. When in automatic test mode, the automatic operation of the storage position needs to be turned on, that is, S-6 is set to 1. The system will run back and forth between S1 and S2 for 2 minutes, then stop for 18 minutes, in an infinite loop.

- Entering method: Press and hold the "UP" + "DOWN" + "SET" buttons for 2 seconds at the same time. At this time, all decimal points of the digital tube are displayed, indicating automatic test mode. To exit the automatic mode, press and hold the "UP" + "DOWN" + "SET" buttons for 2 seconds at the same time.

10、 INTERNAL PARAMETERS AND INSTALLATION DISTANCE SETTINGS

- Press and hold the "SET" button on the hand controller for 5 seconds to enter the setting interface. "S-x" will be displayed and "x" will flash, where "x" is the parameter group. At this time, press "SET" to enter the parameter group to set the corresponding parameters, and press "UP" or "DOWN" to switch parameter groups. After setting the parameters, press the "SET" button to return to the operation interface.
- The parameters that can be set are as follows:
 - a、 "S-1" 0 means metric display, 1 means imperial display.
 - b、 "S-2" Indicates the accuracy of the sensor when encountering an obstruction. 0 means off, 8 is the most sensitive, and 1 is the least sensitive.
 - c、 "S-3" Indicates the accuracy of stopping when the upward current encounters an obstacle. 0 means off, 8 is the most sensitive, and 1 is the least sensitive.
 - d、 "S-4" Indicates the accuracy of stopping the downward current when it encounters an obstacle. 0 means off, 8 is the most sensitive, and 1 is the least sensitive.
 - e、 "S-5" This indicates the installation distance in cm.
 - f、 "S-6" 0 means pressing the storage position key to run and releasing it to stop running; 1 means pressing the storage position key to automatically run to the stored position and any key to stop.
 - g、 "S-7" 0 means turning off the 2-minute and 18-minute working system, and only relying on temperature protection controller, 1 means turning on the 2-minute and 18-minute working system.
 - h、 "S-8" Indicates the left and right tilt of the electric lift actuator, the sensitivity, to prevent the screw rod from breaking or other causes of inconsistent heights of the two electric lift actuators. 0 means off, and 1-8 means a tilt angle of 0.5-4° respectively.

11、 ERROR CODE

Error Code	illustrate	Processing
E01	The main power supply voltage exceeds 45V	Check the main power supply
E02	The height deviation between the screw rods exceeds 1cm	Reinitialization
E04	Hand controller connection or communication error	Check the hand control cable
E05	Stop display	Release the button and restart
E06	The main power supply failed to start, and the voltage is lower than 20V.	Replace the main power supply or check the main power connection cable.
E07	Protection when the main power supply is running, below 20V	Restart the power supply
E08	The electric lift actuator tilts when in operation	Reinitialization
HOT	The power supply temperature is too high, or it runs for more than 2 minutes within 18 minutes.	Wait for the power supply temperature to drop, or let the system rest for 18 minutes before restarting.

E11	Motor 1 not connected	Check the connection cable
E12	Motor 1 current sampling channel error	Replace the control board
E13	Motor 1 is missing phase, and the phase line is disconnected	Check whether the motor phase line connection is abnormal
E14	Motor 1 Hall error, or Hall line disconnected	Check the Hall signal or replace the connecting wire
E15	Motor 1 internal short circuit	Replace the motor
E16	Motor 1 is stalled	Reinitialization
E17	Motor 1 is running in the wrong direction	Replace the motor wire or Hall wire
E18	Motor 1 is overloaded.	Reduce load
E21	Motor 2 not connected	Check the connection cable
E22	Motor 2 current sampling channel error	Replace the control board
E23	Motor 2 is missing phase, and the phase line is disconnected	Check whether the motor phase line connection is abnormal
E24	Motor 2 Hall error, or Hall line disconnected	Check the Hall signal or replace the connecting wire
E25	Motor 2 internal short circuit	Replace the motor
E26	Motor 2 is stalled	Reinitialization
E27	Motor 2 is running in the wrong direction	Replace the motor wire or Hall wire
E28	Motor 2 is overloaded.	Reduce load
E31	Motor 3 not connected	Check the connection cable
E32	Motor 3 current sampling channel error	Replace the control board
E33	Motor 3 is missing phase, and the phase line is disconnected	Check whether the motor phase line connection is abnormal
E34	Motor 3 Hall error, or Hall line disconnected	Check the Hall signal or replace the connecting wire
E35	Motor 3 internal short circuit	Replace the motor
E36	Motor 3 is stalled	Reinitialization
E37	Motor 3 is running in the wrong direction	Replace the motor wire or Hall wire
E38	Motor 3 is overloaded.	Reduce load
E40	A controller in series is offline	Check the connection cable
E41	There is an error in the serial signal	Check the connection cable or replace the controller
E42	Memory Error	Replace the controller
E43	Stop sensor error	Replace the controller

GeMinG Transmission Technology Co., Ltd. - R&D Department