

HTK75

Series
Actuators



HTK75

Series

Linear Actuators

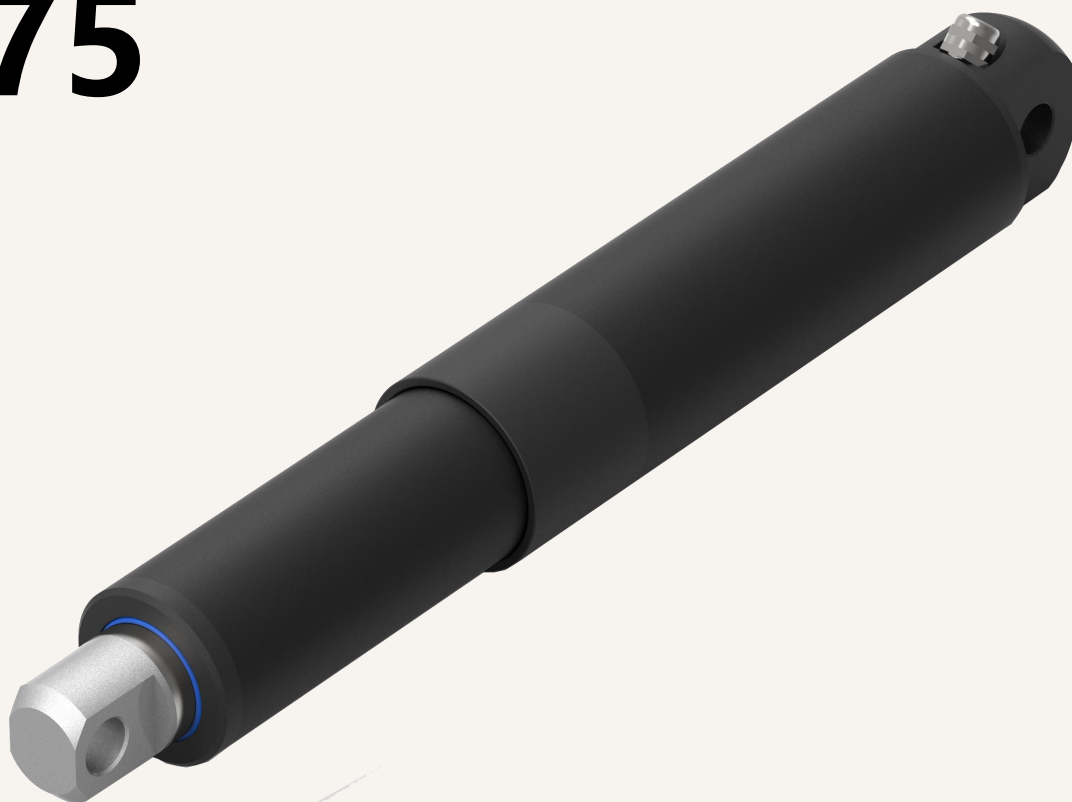

Product Category

- 1、 Industrial application
- 2、 Military application
- 3、 Agricultural machinery
- 4、 Photovoltaics

Download 3D model



K35, K55, and K75 have the same design, all of which are linear linear actuators with a diameter of 75MM, and are mainly used in industrial applications that require heavier loads. It is also very suitable for product applications that require a small installation space. The waterproof rating of this linear actuator can reach up to IP69 (optional). It can withstand high temperature, high pressure water impact, and the ingress of dust and other solid pollutants. It is suitable for construction machinery, photovoltaic tracking systems, ventilation systems, or food and beverage automation equipment...

Functional Overview

Voltage:	12V, 24V, 36V, 48V DC
Motor options:	DC motor, brushless DC motor
Maximum thrust (pull force):	16,000N / 14,000N
Slowest speed under load:	5.0mm/s (load 16,000N)
Maximum speed under load:	90 mm/s (load 1,000N)
Minimum installation size:	Stroke + 500mm
Dynamic lateral moment:	1,000Nm
Static lateral moment:	800Nm
color:	Silver gray, black
Voice:	60~68 DB
Adaptable temperature range:	-45°C ~ +75°C
Protection level:	IP65
Screw selection:	ball screw, trapezoidal screw
Switch type:	Built-in limit switch,
Signal options:	Potentiometer, Hall sensor, endpoint signal
Control options:	Synchronous control, independent control,
safety certificate:	integrated control, CAN bus control,
	Comply with ISO9001-2008,
	CE and RoHS regulations,

Motion Solutions for Clean Energy Applications

Photovoltaic solar energy High energy prices drive double-digit growth in solar energy

Coaxial panel. Solar panel tracking.

Improve efficiency and increase output from a given panel

Accurate, trouble-free positioning of up to 30% more panels

It's a challenge. The system must be rugged and capable

Withstands wind and weather. It must operate reliably and maintenance-free for many years.

Sun tracking requires drive solutions,

Stiff and will not backfire the drive in high wind conditions.



Rear installation can be retrofitted with flange installation

Electric linear actuators for automated guided vehicles, mobile equipment and industrial automation

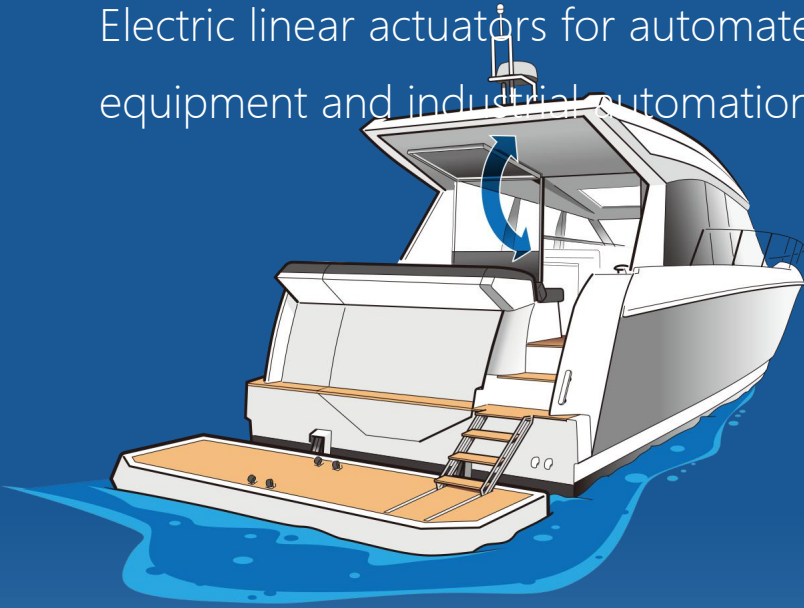

Drawings

Standard size
MM

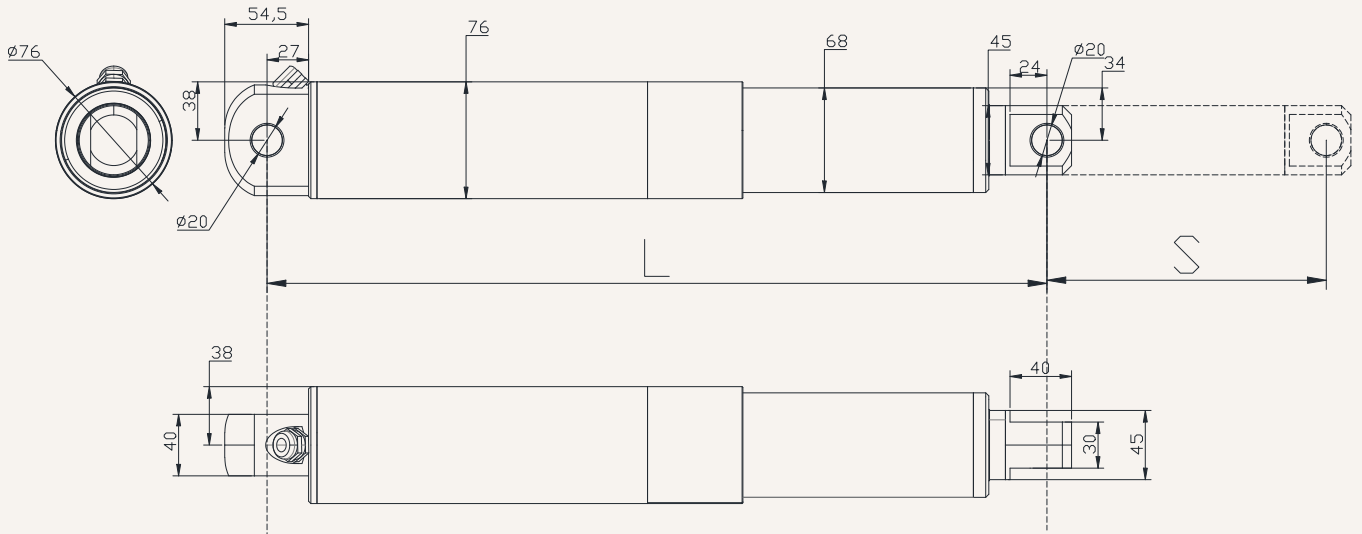

S: Stroke

L: Retracted length

L= Stroke +500mm

Greater than 600MM stroke, installation dimensions L= Stroke +550MM

Installation angle (counterclockwise):

0 =0 Degrees

9 =90 Degrees

G=Adjust at will

load and speed

Code	Rated load Thrust N	Pull N	Self-locking force static conditions static N	Rated load current A	Output speed no load 24V DC mm/s	Rated load 24V DC mm/s
Motor voltage (24V DC)						
A	20,000	20,000	30,000	12.3	2.0	1.8
B	16,000	16,000	25,000	12.3	3.5	2.8
C	10,000	10,000	15,000	12.3	7.0	5.6
D	6,100	6,100	7,100	12.3	9.0	7.5
E	4,200	4,200	4,500	12.3	13	10
F	3,000	3,000	3,200	12.3	19	15
G	2,200	2,200	2,600	12.3	26	21
H	1,500	1,500	2,000	12.3	38	30
I	1,100	1,100	1,200	12.3	50	40
J	600	600	600	12.3	90	80

Remark

1. The speed and current on the upper side are the materials that extend when pushed.
2. For 12V motor, the speed is about the same and the current is about 2 times higher.
3. The current & speed in the table are the test average values in the extension direction under thrust application.
4. The current & speed in the table and graph are the test average values of the GeMinG control box configuration, and there is an error of about 10% depending on the control box model.
(The voltage is about 29V DC at no load, and drops to about 24V DC at rated load)

Stroke: minimum value $\geq 20\text{mm}$, please refer to the table below for the maximum value of load and stroke

load (N)	Maximum stroke (mm)
20,000	50-200
15,000	201-300
12,000	301-400
7,000	401-600
6,000	601-900

Remark:

Lateral moment Y direction = $X \times 0.8$

Static lateral moment = dynamic $\times 2$

Dynamic lateral moment (Nm)-X direction

stroke	S+500	S+550
100-200	800	1000
300-500	600	800
500-700	400	600
700-900	200	400

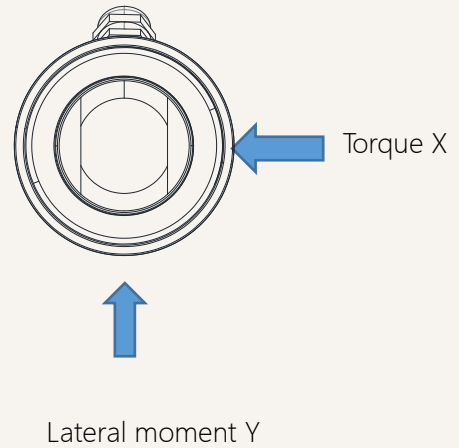

Stroke installation size reference chart

HTK75 Series	stroke ± 2 (mm)					Install ± 2 (mm)				
strokeMM	100	150	200	250	300	350	400	450	500	
Install MM	600	650	700	750	800	850	900	950	1000	
weight KG	8.5	8.8	9.1	9.4	9.7	10.1	10.5	10.9	11.5	

Actuator wiring diagram

No signal feedback wiring diagram

Code: N

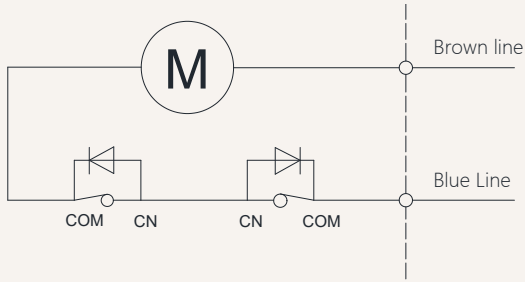

Wiring Instructions:

- 1] Brown lead: motor positive +
- 2] Blue lead: motor negative pole -
- 3] When the push rod is extended: the brown wire is positive +, the blue wire is negative -
- 4] When the push rod is retracted: the blue line is positive +, the brown line is negative -

Signal feedback Passive or active

Passive or active endpoint signal wiring diagram

Code: N passive signal, Code: Y active signal

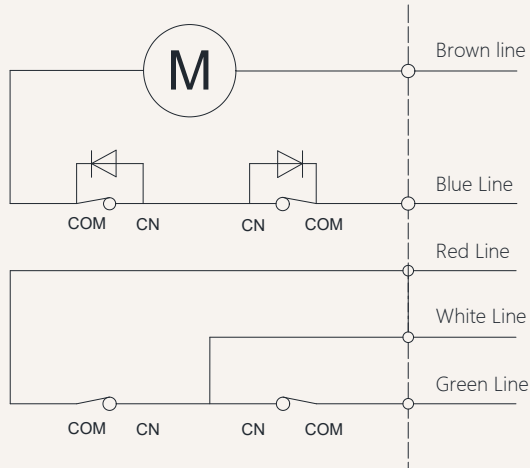

Wiring Instructions:

- 1] Brown lead: positive pole of motor +
- 2] Blue lead: negative pole of motor -
- 3] When the push rod is extended: brown wire positive pole +, blue wire negative pole -
- 4] When the push rod is retracted: blue wire positive pole +, brown wire negative pole -
- 5] White wire: signal output common line.
- 6] White and red wire: extension end signal,
- 7] White and green wire: retraction end signal,

Signal feedback **Hall sensor**

Hall signal motor circuit diagram

Code: H

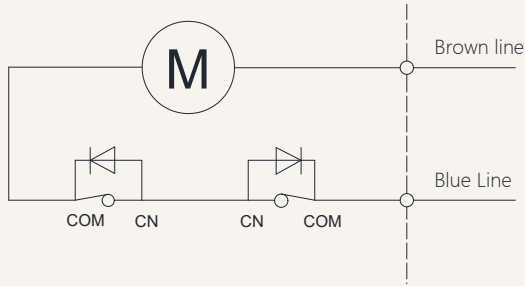

Hall signal output waveform diagram

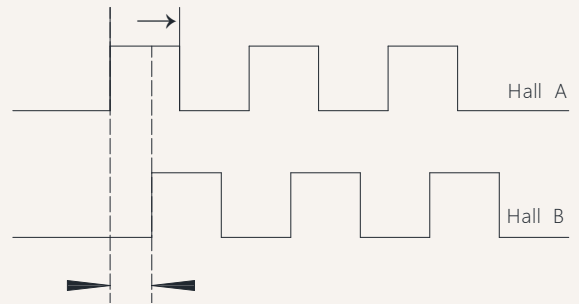

Schematic diagram of the internal circuit of the Hall signal

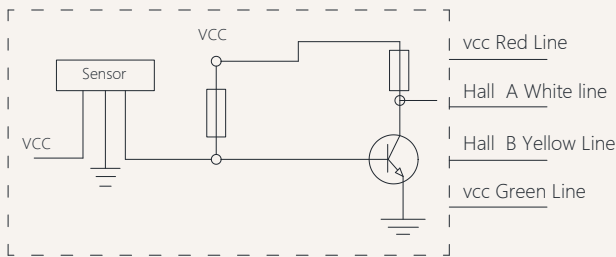

Wiring Instructions:

- 1] Brown lead: positive pole of motor +
- 2] Blue lead: negative pole of motor -
- 3] Red lead: VCC 5V voltage input +
- 4] Green lead: GND 5V voltage input -
- 5] White lead: Hall signal output A
- 6] Yellow lead: Hall signal output B

Notes:

- 1) Support dual-channel/single-channel Hall encoder
- 2) Current-consuming digital output
- 3) High-speed response frequency from: 0 KHz-100 KHz
- 4) Applicable temperature range:-40 °C~+125 °C

Characteristics	Symbol	Test conditions	MI	RE	M	Unit
Supply voltage	Vcc	----	3.5	---	24	V
Output saturation voltage	Vce/sat	Vcc=14V ; Ic=20mA	---	300	700	MV
Output leakage current	1 cex	Vce=14V ; Vcc=14V	---	<0	10	UA
Input voltage	1 ce	Vcc=20V ; Output open	---	1	10	M
Output fall time	R	Vcc=14V ; RL=820Ω ; CL=20pF	---	0.3	1.5	US

Signal feedback CAN bus

CAN Communication motor circuit diagram

Code: CN

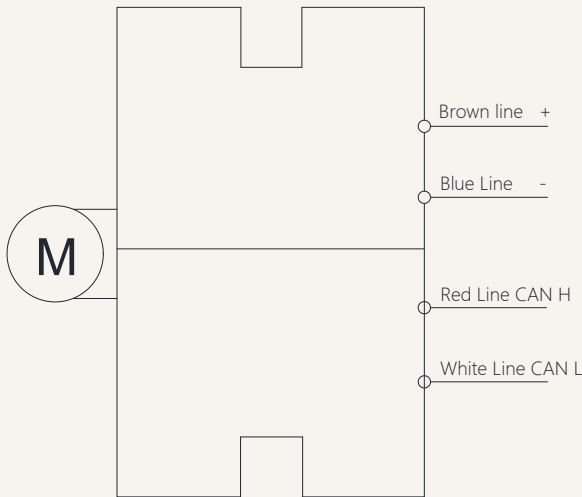

Wiring Instructions:

- 1] Brown lead: positive pole of motor +
- 2] Blue lead: negative pole of motor -
- 3] Red lead: CAN H
- 5] White lead: CAN L

Note:

1. The brown\blue power cord cannot be reversed, otherwise the driver may be burned.
2. With CAN bus, excluding terminal resistor: compliant with J1939
3. Speed: Baud rate: 500kbps

Communication wiring: shielded twisted pair
Cable impedance: 120Ω (+10%)

CAN Control instructions

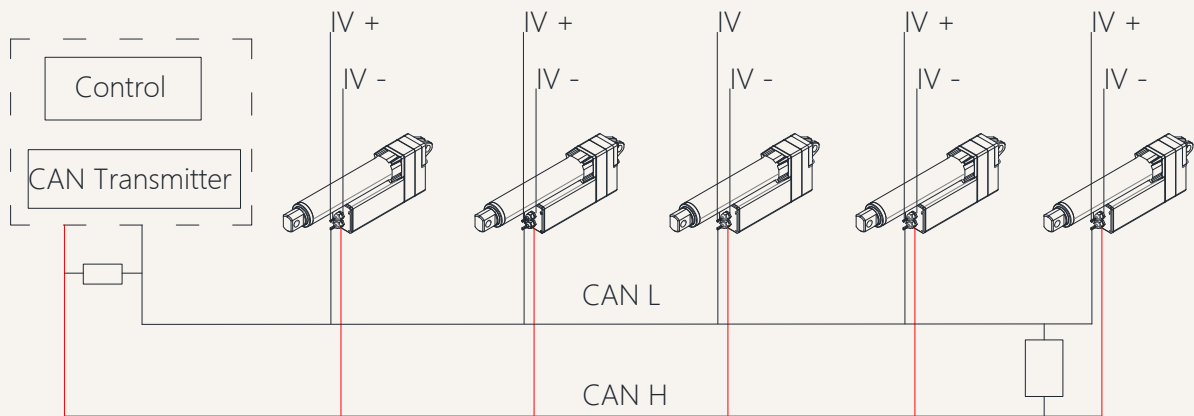

HTK75 Model Description Selection Code Table

HTK75 - 24 A *** *** - O1 O1 0 1 T A N 07
 ① ② ③ ④ ⑤ ⑥ ⑦ ⑧ ⑨ ⑩ ⑪ ⑫ ⑬

①	Product number	HTK75			
②	Voltage	12=12V DC	24=24V DC	36=36V DC	48=48V DC
③	Load(n)@Speed (mm/s)	See page 06			
④	Stroke(mm)	See page 06			
⑤	Installation size(mm)	Note: Before selecting a size, please refer to the valid data sheet! See page 05			
⑥	Upper type	O1 = Ordinary type, hole diameter 20.5mm U1 = Groove width 20.5mm, hole diameter 20.5mm M1 = Type M, M25 thread, depth 20 mm T1 = T-type, M25 thread, length 20mm L1 = L shape, width 20mm, aperture 20.5mm G1 = Spherical bearing, bore 14mm, model GS20	O2 = Ordinary type, hole diameter 25.5mm U2 = Groove width 20.5mm, hole diameter 25.5mm M2 = MType M, M30 thread, depth20 mm T2 = T-type, M30 thread, length 20mm L2 = L shape, width 20mm, aperture 25.5mm G2 = Spherical bearing, bore 16mm, modelGS25		
⑦	lower type	O1 = Ordinary type, hole diameter 20.5mm M1 = Type M, M25 thread, depth 20 mm T1 = T-type, M25 thread, length 20mm G1 = Spherical bearing, bore 20mm, model GS20	O2 = Ordinary type, hole diameter 25.5mm M2 = MType M, M30 thread, depth20 mm T2 = T-type, M30 thread, length 20mm G2 = Spherical bearing, bore 25mm, modelGS25		
⑧	Installation angle (counterclockwise)	0 =0°, Degree	9 =90°, Degree		
⑨	Please refer to the outlet type	12 = 2 core bare wire 4 = four-pin straight plug 7 = waterproof plug	25 = 7 core bare wire 6 = Six-pin straight plug K = Customization		
⑩	Lead screw options	G=Ball screw (default preferred)	T = Trapezoidal screw		
⑪	Control method	A = No control T = Synchronous control	C = CAN bus K = Customized	Y =***	N=***
⑫	Signal output options	N = None W=passive signal	H = Hall sensor AN = CAN communication	D =***	U=***
⑬	Cable length	07 =Cable length 0.7 M 30 =Cable length 3.0 M 70 =Cable length 7.0 M	10 = Cable length 1.0 M 40 =Cable length 4.0M 70 =Cable length 8.0 M	15 =Cable length 1.5 M 50 =Cable length 5.0 M 90 =Cable length 9.0 M	20= Cable length 2.0 M 60= Cable length 6.0M 00 =Customization

HTK75 Attachment Description Selection Code Table

Extended upper form:

O1=No slot, aperture 20.5MM

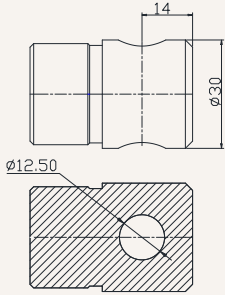

O2=No slot, aperture 25.5MM

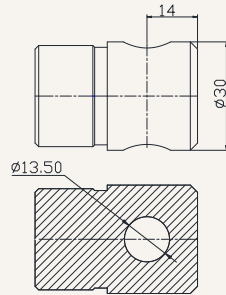

U1 = U-shaped, groove width 20.5mm, hole diameter 20.5mm

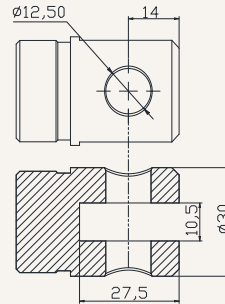

U2 = U-shaped, groove width 20.5mm, hole diameter 25.5mm

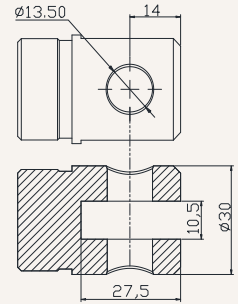

M1 = Type M, M25 thread, depth 20 mm

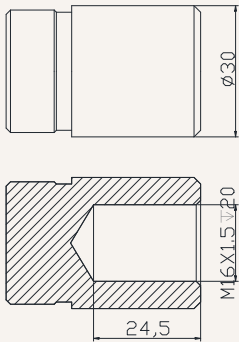

M2 = Type M, M30 thread, depth 20 mm

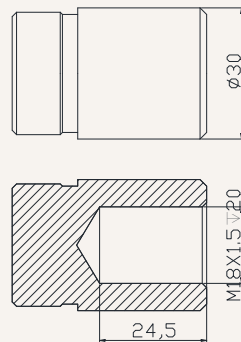

T1 = T-type, M25 thread, length 24mm

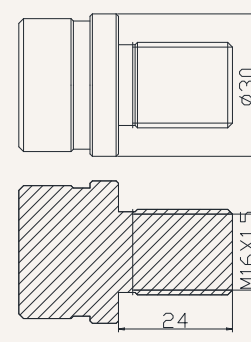

T2 = T-type, M35 thread, length 24mm

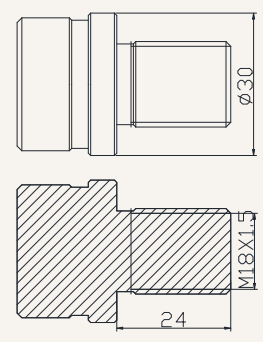

L1 = L shape, width 20mm, aperture 20.5mm

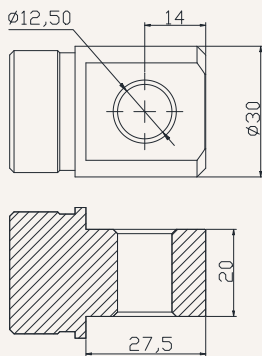

L2 = L shape, width 20mm, aperture 25.5mm

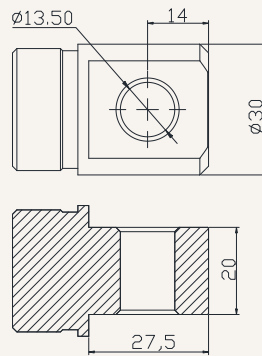

G1 = Spherical bearing, bore 20mm, model GS20

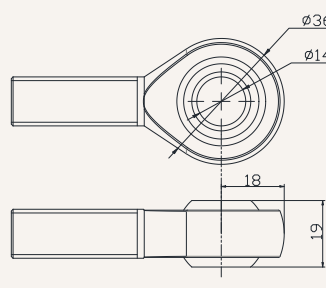

G2 = Spherical bearing, bore 25mm, model GS25

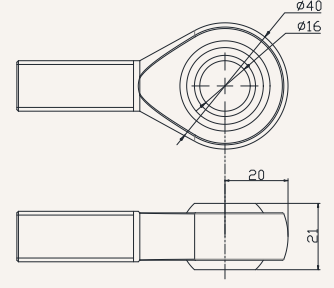

Power cord type:

1 =Dare wire

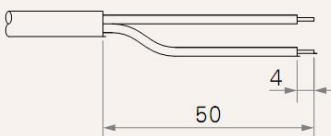

2 = 01 Straight plug

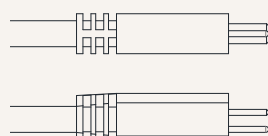

4 =Four-pin straight plug

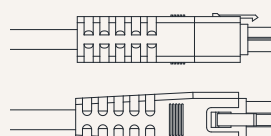

6 = Six-pin straight plug

