

TDS

Series
Rising bollards

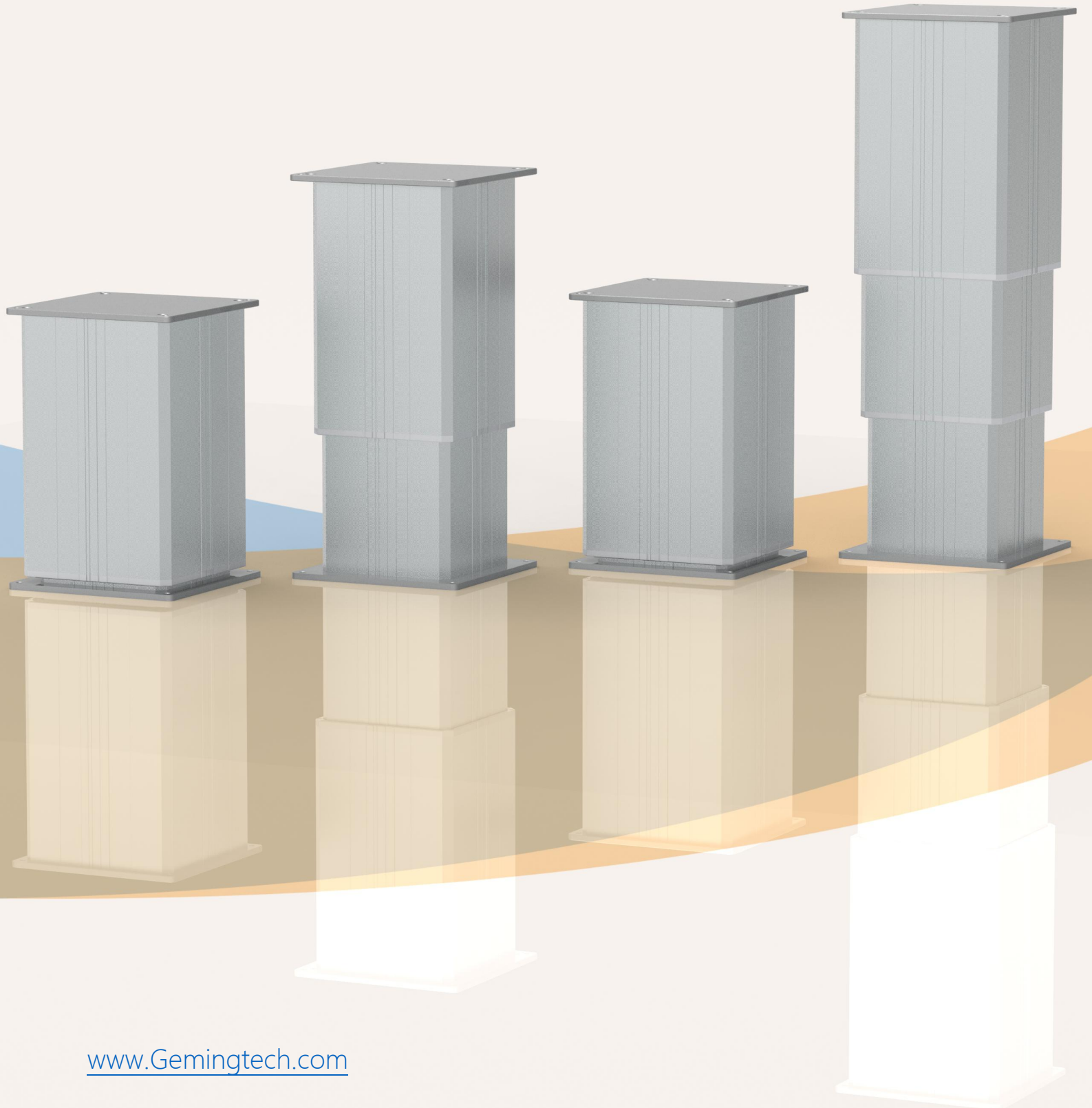

TDS2

Series

Electric rising bollard



TDS3

Series

Electric rising bollard

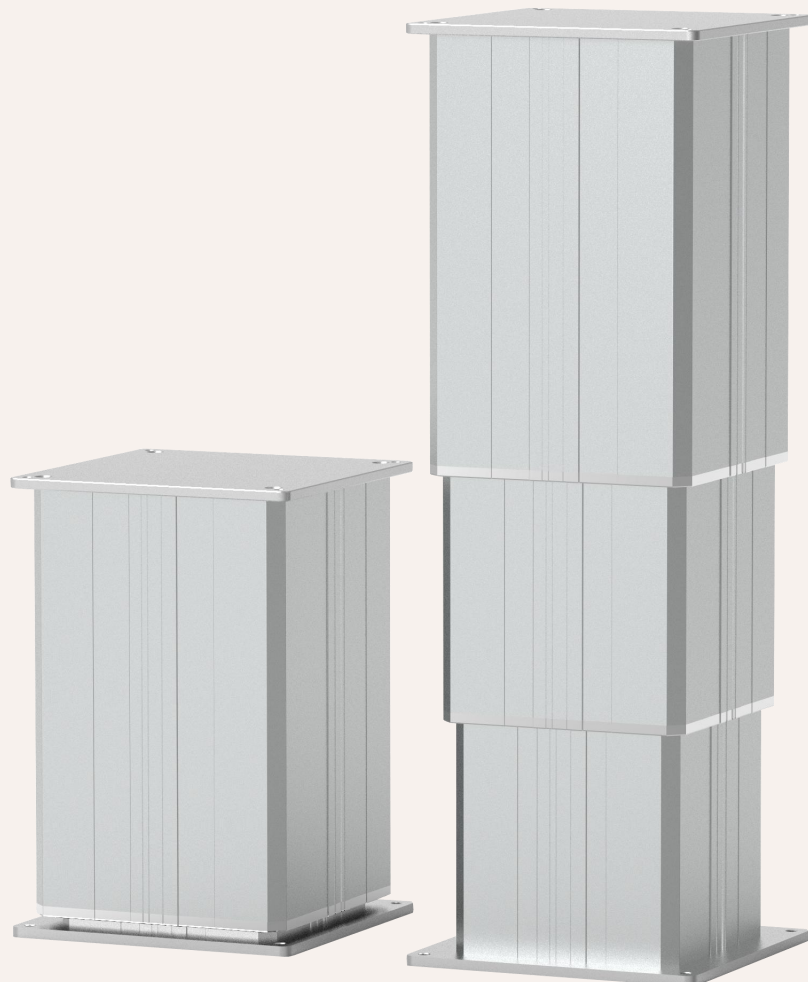

Load & Speed Reference Chart

Speed ratio speed code	J	I	H	G	F	E	D	C	B	A
model:TDS2										
220VAC load push-pull force (N)	1,000	1,200	1,600	2,000	3,000	4,000	5,000	6,000	8,000	10,000
Load speed (MM/S)	100	85	75	60	40	30	24	20	15	10

Maximum load current: 48VDC (maximum 53VDC) = 8A, 220VAC (maximum 240VAC) = 2.5A

model:TDS3										
220VAC load push-pull force (N)		800	1,000	1,300	1,600	2,000	2,500	3,200	4,000	5,000
Load speed (MM/S)		100	80	60	48	40	30	24	20	15

Maximum load current: 48VDC (maximum 53VDC) = 8A, 220VAC (maximum 240VAC) = 2.5A

TDS2 series					TDS3 series			
S stroke MM	150	200	250	300	300	400	500	600
L Installation dimensions	350	400	450	500	375	400	500	550
S+L unfolding height	500	600	700	800	675	800	1000	1150

Product Category

- 1、 Industrial applications
- 2、 Medical applications
- 3、 Furniture application

The TDS is one of GeMin's height-adjustable column products, professionally designed for medical and working environments such as hospital beds, home care beds, treatment tables, and height-adjustable workstations. The TDS3 features a three-section outer tube that provides stable operation and offers minimal installation dimensions as well as a long travel range.

Function Overview

Voltage:	48V DC, 220V AC
Motor options:	DC motor, AC motor
Maximum thrust (pull):	8,000 N / 4,000N
Slowest speed under load:	15mm / s (load 8,000N)
Maximum speed under load:	60 mm / s (load 2000N)
Minimum installation size:	stroke /2 + 200mm
Dynamic lateral moment:	2000Nm
Static lateral moment:	3500Nm
color:	Silver gray, black
Voice:	48~58 DB
Temperature range:	-25 ° C ~ + 65 ° C
Protection level:	IP54
Screw selection:	Trapezoidal Screw
Switch type:	Built-in limit switch
Signal options:	Hall sensor, endpoint signal
Control options:	Synchronous control, independent control, integrated control, CAN bus control
Security Certification:	Comply with ISO9001-2008.
High-strength zinc alloy gearbox and housing,	CE and RoHS standards

TDS2-Engineering drawings

Standard size
MM

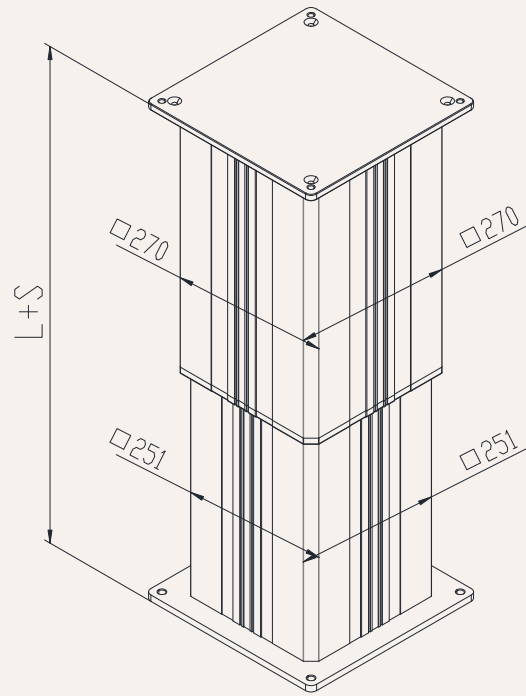
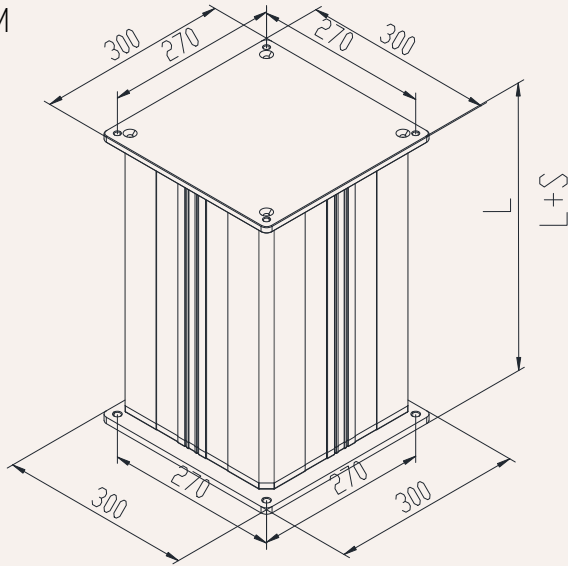

- S= Stroke
- L= Retracted length
- L= Stroke +200mm

TDS3-Engineering drawings

Standard size
MM

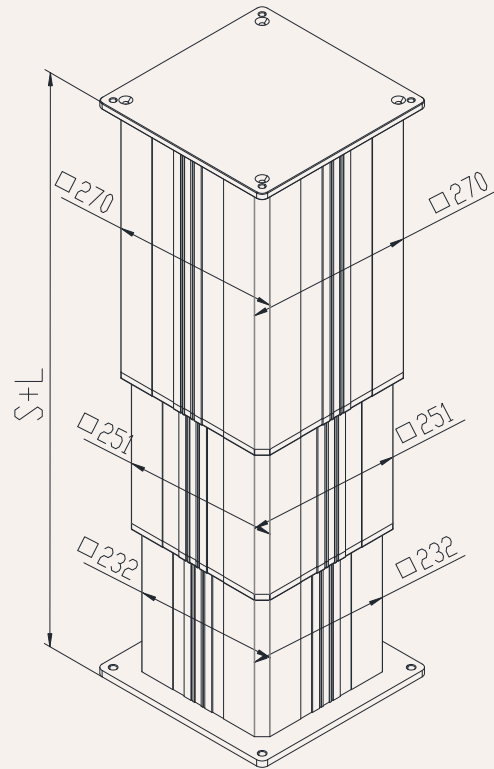
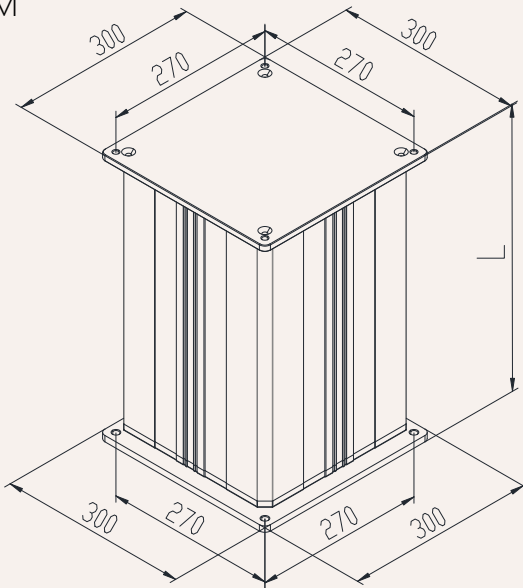

- S= Stroke
- L= Retracted length
- L= Stroke /2 +250mm

Medical actuator application systems

Precise, powerful, fast, and flexible operation

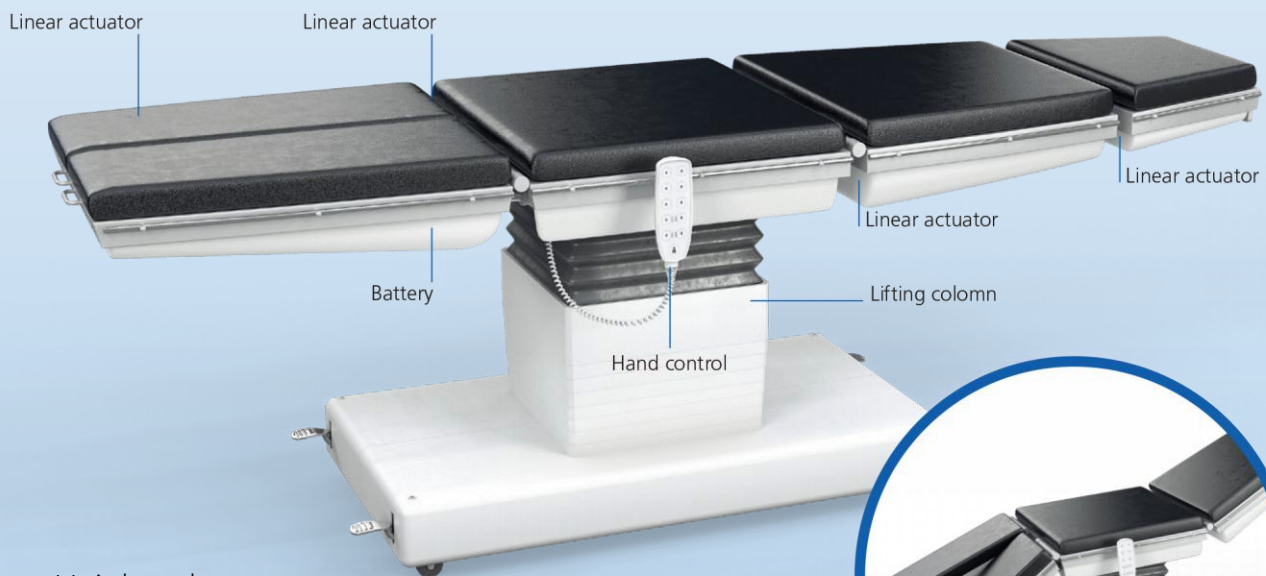

Height adjustment

Positioning adjustment

More compact design

This makes it easier to install in small spaces.

Ideal for designing different types of automated equipment

Automated guided vehicles and lifting equipment

At the same time, it retains many of its popular advantages!

Standard stroke: Minimum $\geq 20\text{mm}$. Please refer to the table below for maximum load and stroke.

load(N)	Maximum travel(mm)
8,000	200-300
6,000	301-400
4,000	401-500
3,000	501-600
2,000	601-900

Remark:

Lateral torque in the Y direction = $X * 0.8$

Static lateral moment = dynamic * 2

Dynamic lateral torque (Nm) - X direction

stroke	S/2+250	S/2+300
100-300	2000	3000
300-500	1500	2000
500-700	1200	1500
700-900	1000	1200

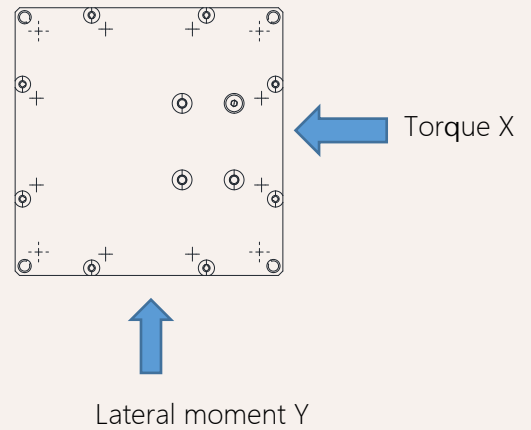

Installation Dimensions Reference Chart

TDS2 series					TDS3 series			
S stroke MM	150	200	250	300	300	400	500	600
L Installation dimensions	350	400	450	500	375	400	500	550
S+L unfolding height	500	600	700	800	675	800	1000	1150

Actuator wiring diagram

Wiring diagram without signal feedback

code: N

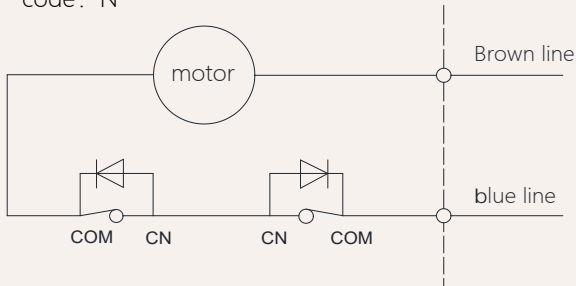

Wiring instructions: :

- 1] Brown lead wire: Motor positive terminal +
- 2] Blue lead wire: Motor negative terminal -
- 3] When the putter extends: Brown wire is positive +, blue wire is negative -
- 4] When the push rod retracts: blue wire is positive (+), brown wire is negative (-).

Actuator wiring diagram Built-in control module

Wiring diagram of built-in controller

code: Y

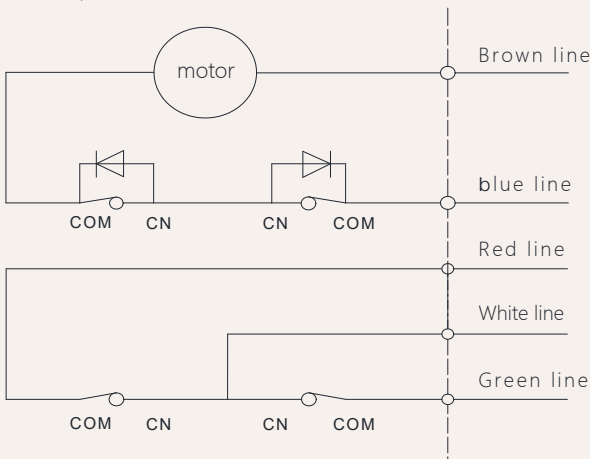

Wiring instructions: :

- 1] Brown lead wire: Motor positive terminal +
- 2] Blue lead wire: Negative terminal of the motor -
- 3] When the putter extends: white line + red line
- 4] When the putter retracts: white line + green line
- 5] White line: Common line for control output.
- 6] White and red lines: extending outwards.
- 7] White and green lines: retraction.
- 8] Wireless remote control, which can be used in conjunction with wired control.

Other signal descriptions

Feedback signal

illustrate

Function

Active endpoint feedback signal With voltage of this model

The push rod sends a feedback signal when it reaches its endpoint. This signal remains active and only disappears during the push rod's operation.

Passive endpoint feedback signal No voltage

The push lever sends a feedback signal when it reaches the end point. This signal is always present when the input power is not turned off, and disappears when the input power is turned off. The signal will also disappear during operation.

Note: For other needs, please contact the GeMinG team.

Signal feedback **Hall effect sensor**

Hall effect signal motor circuit diagram

code: H

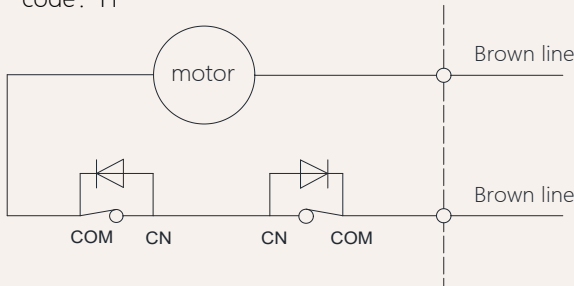

Hall signal output waveform diagram

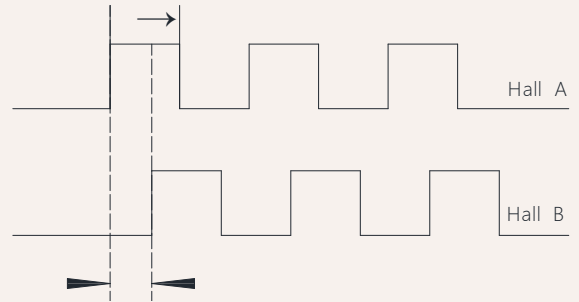

Hall effect signal internal circuit diagram

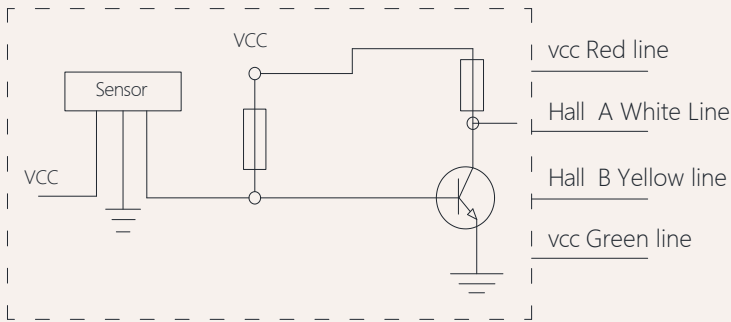

Wiring instructions:

Wiring instructions:

- 1] Brown lead wire: positive terminal of the motor +
- 2] Blue lead wire: Negative terminal of the motor -
- 3] Red lead: VCC 5V voltage input +
- 4] Green lead: GND 5V voltage input -
- 5] White lead: Hall signal output A
- 6] Yellow lead: Hall signal output B

Remark:

- 1) Supports dual-channel/single-channel Hall encoders
- 2) Current-consuming digital output
- 3) High-speed response frequency from: 0 KHz-100 KHz
- 4) Applicable temperature range: -40 °C~+125 °C

characteristic	symbol	Test conditions	MI	RE	M	unit
Supply voltage	Vcc	----	3.5	---	24	V
Output saturation voltage	Vce/sat	Vcc=14V ; Ic=20mA	---	300	700	MV
Output leakage current	1 cex	Vce=14V ; Vcc=14V	---	<0	10	UA
Input voltage	1 ce	Vcc=20V ; Output open	---	1	10	M
Output fall time	R	Vcc=14V ; RL=820Ω ; CL=20pF	---	0.3	1.5	US

TDS Model Explanation Selection Code Table

TDS2 - 48 A *** *** - O1 O1 0 1 T N N 30
 ① ② ③ ④ ⑤ ⑥ ⑦ ⑧ ⑨ ⑩ ⑪ ⑫ ⑬

①	Model Prefix	TDS2 = Two-stage	TDS3 = Three-section	
②	Voltage	48= 48V DC	22= 220V AC	
③	Loading (n) @ Speed (mm/s)			
④	stroke(mm)			
⑤	Installation dimensions(mm)	Note: Please refer to the valid parameter table before selecting a size!		
⑥	Upper type	O1 = For standard pipe types, M8 mounting screws are countersunk by 30mm. K = Customization	O2 = Enlarged panel type, 8mm mounting holes.	
⑦	Lower type	O1 = For standard pipe types, M8 mounting screws are countersunk by 30mm. K = Customization	O2 = Enlarged panel type, 8mm mounting holes.	
⑧	Qualifying Position	0=upper plate top	1=upper side	2=lower side
		4=Side of the inner wiring	5=inner side of the line	
⑨	Type of qualification	1 =bare wire	2 = 01 Straight plug	4 =Four-pin straight insertion
		7 =Waterproof plug	0=Servo standard drive cable	6 = Six-pin straight insertion
		K =Customization		
⑩	Screw options	T = Trapezoidal Screw (Default preferred)		G = ball screw
⑪	Control method	N= No control required	C = CAN communication control	T = Synchronization control
		Y =Integrated wired control	W=Integrated wireless remote control	K = Customization
⑫	Signal output options	N = 0	H =Hall effect sensors	U=Active signal
		AN = CAN communication		
⑬	Line length	07 =Line length 0.7 M	10 = Line length1.0 M	15 =Line length 1.5 M
		30 =Line length 3.0 M	40 =Line length 4.0M	50 =Line length 5.0 M
		70 =Line length 7.0 M	70 =Line length 8.0 M	90 =Line length 9.0 M
				20= Line length 2.0 M
				60= Line length 6.0M
				00 =Customization