

HTB60

Series

Linear Actuators



Product Category

- 1、 medical applications
- 2、 furniture application

Download 3D model



TB60 is one of the new generation medical furniture actuators developed by GeMinG. It is suitable for medical applications, such as electric hospital beds, home care beds and other different uses. The waterproof level can reach up to IP65. In addition, it complies with important safety regulations in medical applications. Other options include quick release functions designed for emergency situations, dual Hall sensors or reed switches and other signal outputs, such as: medical slings, furniture, seats, and various equipment. actuator

Functional Overview

Voltage:	12V, 24V, DC
Motor options:	DC motor, brushless DC motor
Maximum thrust (pull force):	6,000N / 4,000N
Slowest speed under load:	5.0mm/s (load 6,000N)
Maximum speed under load:	22mm/s (load 1,000N)
Minimum installation size:	Stroke + 250mm
Dynamic lateral moment:	500Nm
Static lateral moment:	800Nm
color:	Silver gray, black
Voice:	45~50 DB
Adaptable temperature range:	-25°C ~ +65°C
Protection level:	IP65
Screw selection:	trapezoidal screw
Switch type:	Built-in limit switch,
Signal options:	Hall sensor,
Control options:	Synchronous control, independent control, integrated control,
safety certificate:	Comply with ISO9001-2008,
High-strength metal zinc alloy gearbox and housing,	CE and RoHS regulations,



KNOWLEDGE



GLOBAL
PRESENCE



INNOVATION



PARTNERSHIP



LEAN
WORLD-CLASS
PRODUCTION



SAFETY

Choosing an actuator that meets the application requirements is important!

4

Required thrust

At GeminG, technical experts will work with you throughout the project to provide the best solution for your application. With a rich vertical integration business model, GeminG provides highly customized solutions to meet the special needs of various applications, ensuring that the integration of electric linear drive systems is tight and efficient.

Drawings

Standard size
MM

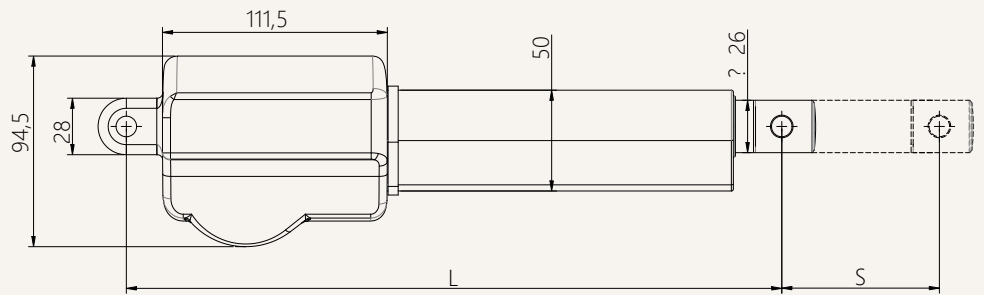
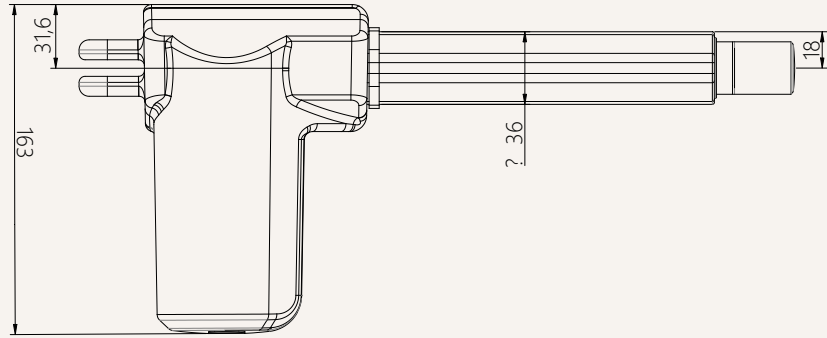
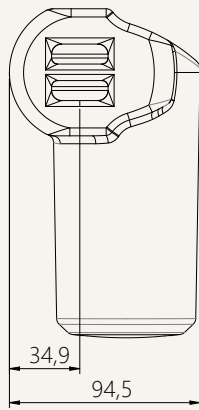

S: Stroke

L: Retracted length

L = Stroke + 175mm

Greater than 500MM stroke, installation dimensions L = Stroke + 190MM

Installation angle (counterclockwise):

0 = 0 Degrees

4 = 45 Degrees

9 = 90 Degrees

3 = 135 Degrees

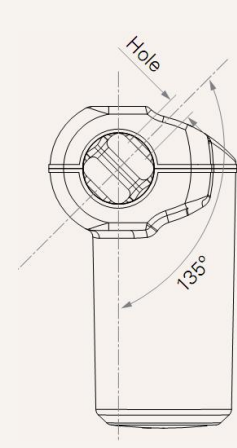
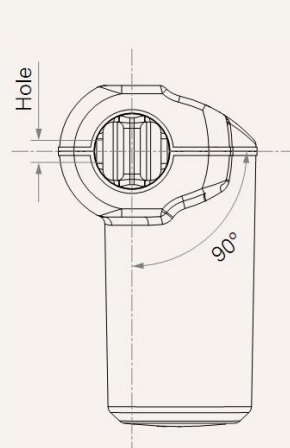
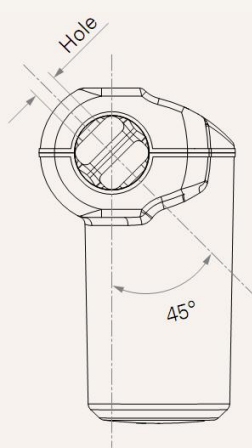
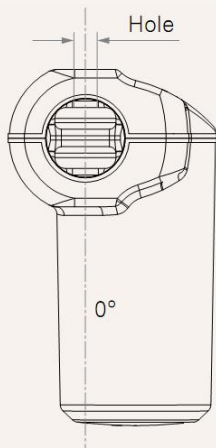

load and speed

Code	Rated load Thrust N	Pull N	Self-locking force static conditions static N	Rated load current A	Output speed no load 24V DC mm/s	Rated load 24V DC mm/s
Motor voltage (24V DC)						
A	6000	4000	6000	5.4	5.7	4.3
B	5000	4000	3000	5.4	11.3	8.7
C	4000	4000	2500	4.7	17.0	13.5
D	3000	3000	1000	4.7	22.7	17.0
E	2000	2000	800	4.1	34.0	25.6

Remark

1. The speed and current on the upper side are the materials that extend when pushed.
2. For 12V motor, the speed is about the same and the current is about 2 times higher.
3. The current & speed in the table are the test average values in the extension direction under thrust application.
4. The current & speed in the table and graph are the test average values of the GeMinG control box configuration, and there is an error of about 10% depending on the control box model.
(The voltage is about 29V DC at no load, and drops to about 24V DC at rated load)

Stroke: minimum value $\geq 20\text{mm}$, please refer to the table below for the maximum value of load and stroke

load (N)	Maximum stroke (mm)
6,000	50-200
4,000	201-500
3,000	501-600
2,000	601-800
1,000	801-900

Remark:

Lateral moment Y direction = $X \times 0.8$

Static lateral moment = dynamic $\times 2$

Dynamic lateral moment (Nm)-X direction

stroke	S+175	S+190
100-200	200	300
300-500	150	250
500-700	100	200
700-900	80	100

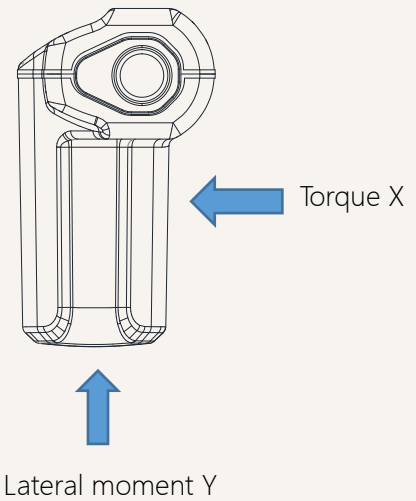

Stroke installation size reference chart

HTB60 Series	stroke ± 2 (mm)					Install ± 2 (mm)				
strokeMM	100	150	200	250	300	350	400	450	500	
Install MM	275	325	375	425	475	525	575	625	690	
weight KG	1.5	1.8	2.1	2.4	2.7	3.1	3.2	3.6	3.8	

Actuator wiring diagram

No signal feedback wiring diagram

Code: N

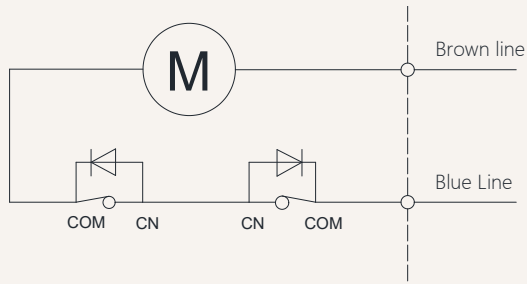

Wiring Instructions:

- 1] Brown lead: motor positive +
- 2] Blue lead: motor negative pole -
- 3] When the push rod is extended: the brown wire is positive +, the blue wire is negative -
- 4] When the push rod is retracted: the blue line is positive +, the brown line is negative -

Actuator wiring diagram Built-in control module

Built-in controller wiring diagram

Code: NY

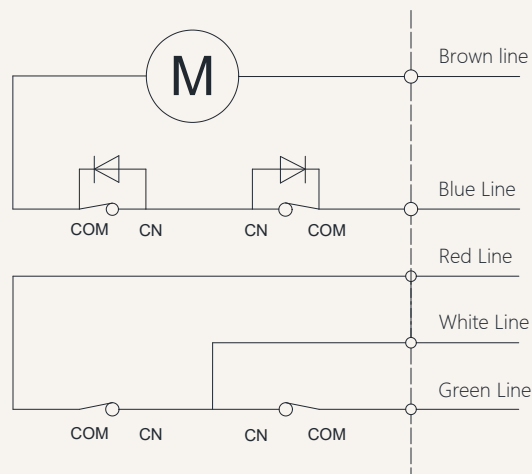

Wiring Instructions:

- 1] Brown lead: motor positive +
- 2] Blue lead: motor negative pole -
- 3] When the push rod is extended: white line + red line
- 4] When the push rod retracts: white line + green line
- 5] White line: control output common line.
- 6] White and red lines: stretch out,
- 7] White and green lines: retract,
- 8] Wireless remote control, use wired control simultaneously.

Other signal descriptions

Feedback signal	Description	Function
Active endpoint feedback signal	Voltage with this model	When the push rod reaches the end point, a signal will be fed back. This signal will always exist and will disappear during the operation of the push rod., When the push rod reaches the end point, it will feedback a signal. This signal always exists when the input power is not turned off. When the input power is turned off, the signal disappears. The signal will also disappear during the operation.
Passive endpoint feedback signal	No voltage	

Note: For other needs, please contact the GeMinG team

Signal feedback Hall sensor

Hall signal motor circuit diagram

Code: H

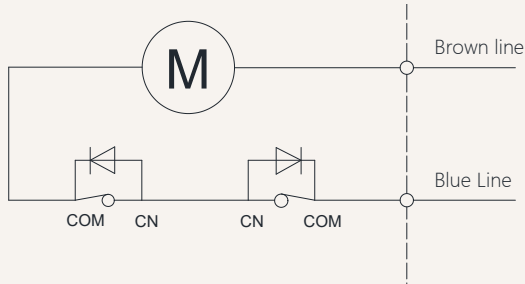

Hall signal output waveform diagram

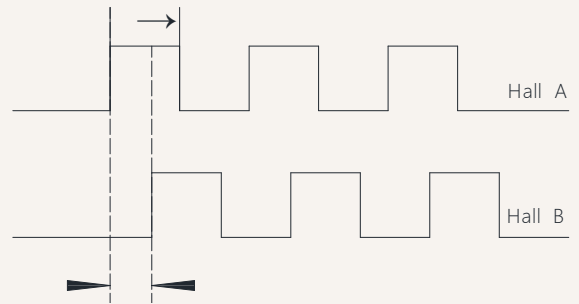

Schematic diagram of the internal circuit of the Hall signal

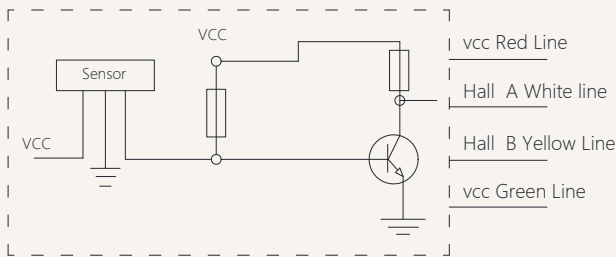

Wiring Instructions:

- 1] Brown lead: positive pole of motor +
- 2] Blue lead: negative pole of motor -
- 3] Red lead: VCC 5V voltage input +
- 4] Green lead: GND 5V voltage input -
- 5] White lead: Hall signal output A
- 6] Yellow lead: Hall signal output B

Notes:

- 1) Support dual-channel/single-channel Hall encoder
- 2) Current-consuming digital output
- 3) High-speed response frequency from: 0 KHz-100 KHz
- 4) Applicable temperature range:-40 °C~+125 °C

Characteristics	Symbol	Test conditions	MI	RE	M	Unit
Supply voltage	Vcc	----	3.5	---	24	V
Output saturation voltage	Vce/sat	Vcc=14V ; Ic=20mA	---	300	700	MV
Output leakage current	1 cex	Vce=14V ; Vcc=14V	---	<0	10	UA
Input voltage	1 ce	Vcc=20V ; Output open	---	1	10	M
Output fall time	R	Vcc=14V ; RL=820Ω ; CL=20pF	---	0.3	1.5	US

HTB60 Model Description Selection Code Table

HTB60 - 24 A *** *** - O1 O1 0 1 T A N 07
 ① ② ③ ④ ⑤ ⑥ ⑦ ⑧ ⑨ ⑩ ⑪ ⑫ ⑬

①	Product number	HTB60			
②	Voltage	12=12V DC	24=24V DC	36=36V DC	48=48V DC
③	Load(n)@Speed (mm/s)	See page 06			
④	Stroke(mm)	See page 06			
⑤	Installation size(mm)	Note: Before selecting a size, please refer to the valid data sheet! See page 05			
⑥	Upper type	O1 = Ordinary type, hole diameter 10.5mm U1 = Groove width 8.5mm, hole diameter 10.5mm M1 = Type M, M14 thread, depth 20 mm T1 = T-type, M14 thread, length 20mm L1 = L shape, width 18mm, aperture 10.5mm	O2 = Ordinary type, hole diameter 12.5mm U2 = Groove width 8.5mm, hole diameter 12.5mm M2 = MType M, M16 thread, depth20 mm T2 = T-type, M16 thread, length 20mm L2 = L shape, width 18mm, aperture 12.5mm		
⑦	lower type	O1 = Ordinary type, hole diameter 10.5mm P1 = Flat bottom 4 M4 screws	O2 = Ordinary type, hole diameter 12.5mm		
⑧	Installation angle (counterclockwise)	0 =0°, Degree 4 =45, Degree	9 =90°, Degree 3 =135, Degree		
⑨	Please refer to the outlet type	12 = 2 core bare wire 4 = four-pin straight plug 7 = waterproof plug	25 = 7 core bare wire 6 = Six-pin straight plug K = Customization		
⑩	Lead screw options	G=Ball screw (default preferred)	T = Trapezoidal screw		
⑪	Control method	A = No control T = Synchronous control	C = CAN bus K = Customized	Y =***	N=***
⑫	Signal output options	N = None W=passive signal	H = Hall sensor AN = CAN communication	D =***	U=***
⑬	Cable length	07 =Cable length 0.7 M 30 =Cable length 3.0 M 70 =Cable length 7.0 M	10 = Cable length 1.0 M 40 =Cable length 4.0M 70 =Cable length 8.0 M	15 =Cable length 1.5 M 50 =Cable length 5.0 M 90 =Cable length 9.0 M	20= Cable length 2.0 M 60= Cable length 6.0M 00 =Customization

HTA28 Attachment Description Selection Code Table

Upper end form (extended):

O1=Ordinary type, hole diameter 6.1mm

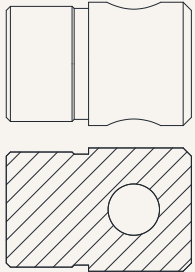

O2=Ordinary type, hole diameter 8.1mm

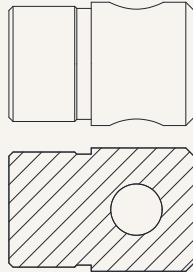

U1 = groove width 8.1mm, hole diameter 6.1mm

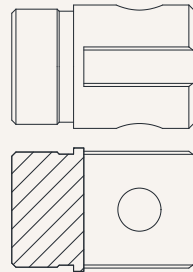

U2 = groove width 8.1mm, hole diameter 8.1mm

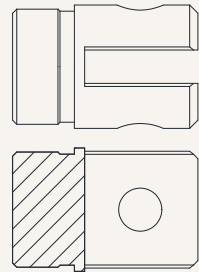

M1 = Type M, M12 thread, depth 20 mm

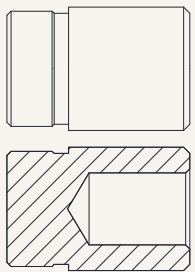

M2 = Type M, M14 thread, depth 20 mm

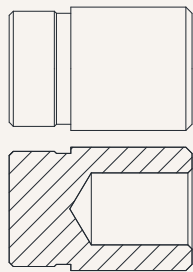

T1 = T-type, M12 thread, length 20mm

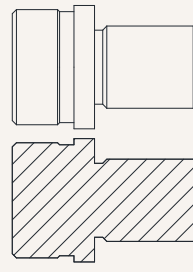

T2 = T-type, M14 thread, length 20mm

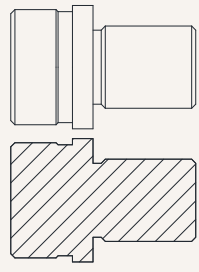

L1 = L shape, width 6mm, aperture 6.1mm

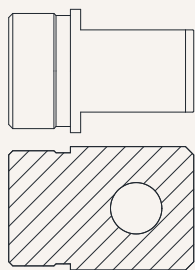

L2 =L shape, width 6mm, aperture 8.1mm

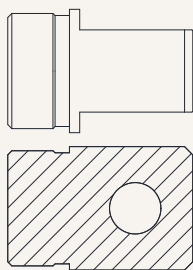

KZ = Customized

Power Cord Plug Type Code Table

1 = Bare wire

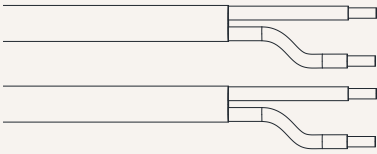

2 = O1 Straight plug

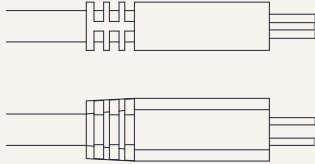

3 = 4-pin angled plug

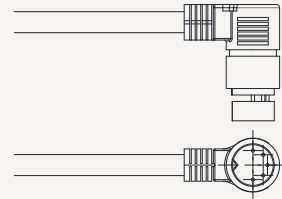

4 = 4-pin straight plug

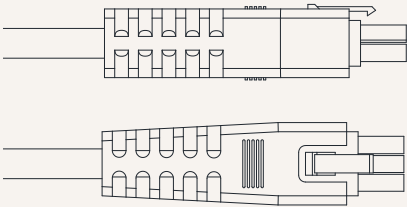

8 = Waterproof plug

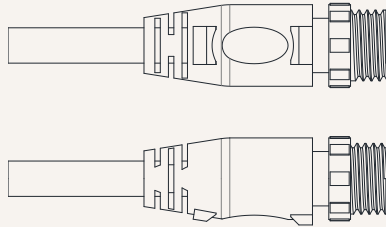

9 = 6-pin straight plug

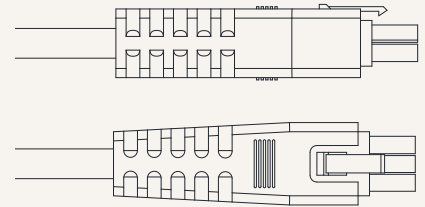

0 = Customized

Terms of Use

The user is responsible for determining the suitability of GeMinG products for a specific application.

GeMinG products are subject to change without prior notice.